

WHEN DISASSEMBLING ALUMINUM EXTRUSION, TIGHTEN ALL SETSCREWS AND LOCKS TO PREVENT LOSS DURING SHIPPING

visionary™ IDESIGNS

Using Your Setup Instructions

The Visionary Designs Setup Instructions are created specifically for your configuration. They are laid out sequentially, including an exploded view of the entire display, and then a logical series of detailed steps to assemble the main structure and components. We encourage you to study the instructions **before** attempting to assemble your exhibit.

Each page reminds you to tighten the setscrews after disassembling your exhibit to prevent loss of the locks and setscrews (see below in RED). This is **VERY IMPORTANT**.

Cleaning and Packing Your Display

- 1) Use care when cleaning aluminum extrusion or acrylic inserts. Use only non-abrasive cleaners.
- 2) When cleaning laminate inserts or countertops, use mild cleansers and a soft material such as cotton.
- 3) Keep all display components away from extreme heat and long exposure to sunlight to avoid warping and fading.
- 4) Retain all packing material. It will make re-packing much easier and will reduce the likelihood of shipping damage.



The Tool

Most Visionary Designs exhibits can be assembled with the supplied Hex Key Tool. Occasionally, a flat head screwdriver may be required.



Typical Connection

Most horizontal extrusion connections have a patented expandable lock. This lock inserts into the groove of an opposing extrusion. Tightening the lock with the Hex Key Tool expands the lock and creates a strong positive connection.



Typical Connection (cont'd)



Detail B

Numbered Label

Each extrusion contains a numbered label which corresponds with setup instructions. The label is located within a groove of the extrusion (when possible). With Visionary Designs the labels contain Black numbers unless otherwise specified.



Detail C

Horizontal Inline Connection (remove only one setscrew)

Remove only (1) setscrew when disassembling. Replace setscrew in extrusion after assembling it. Before packing, replace setscrew in extrusion to avoid losing it.

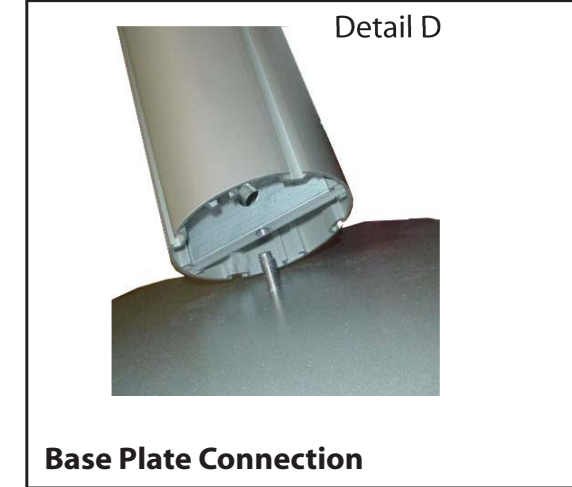

Detail D

Base Plate Connection

Attach base plate to round or square vertical extrusion using the bolt provided. Be careful not to strip the threads.

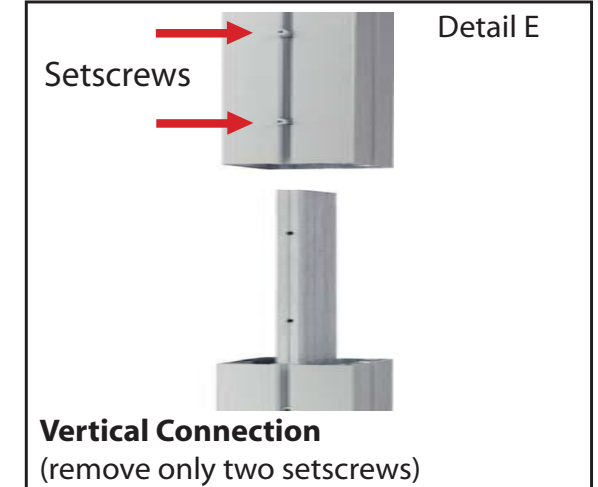

Detail E

Vertical Connection
(remove only two setscrews)

When vertical extrusions are packed in portable cases rather than crates or tubs, they must be broken down into smaller sections which then require assembly.

Remove only (2) setscrews when disassembling. Replace setscrews in extrusion after assembling it. Before packing, replace setscrews in extrusion to avoid losing them.

WHEN DISASSEMBLING ALUMINUM EXTRUSION, TIGHTEN ALL SETSCREWS AND LOCKS TO PREVENT LOSS DURING SHIPPING

Part Number	Qty for Step	Description
1	2	Base Plates
1a	1	Base Plates
2	2	46h Lower Vertical extrusion
3	2	46" Upper Vertical extrusion
4	1	48h Lower Vertical extrusion
5	1	48" Upper Vertical extrusion
6	2	26.577" Curved Horizontal Extrusion
7	2	26.577" Curved Horizontal Extrusion

Steps

- 1) Attach vertical extrusions to base plates [2 to 1 and 4 to 1a].
- 2) Attach upper vertical extrusions to lower vertical extrusions [3 to 2 and 5 to 4].
- 3) Attach curved horizontal extrusions between vertical assemblies as shown.
- 4) Apply graphic to assembled backwall, see Attaching Graphics Note.

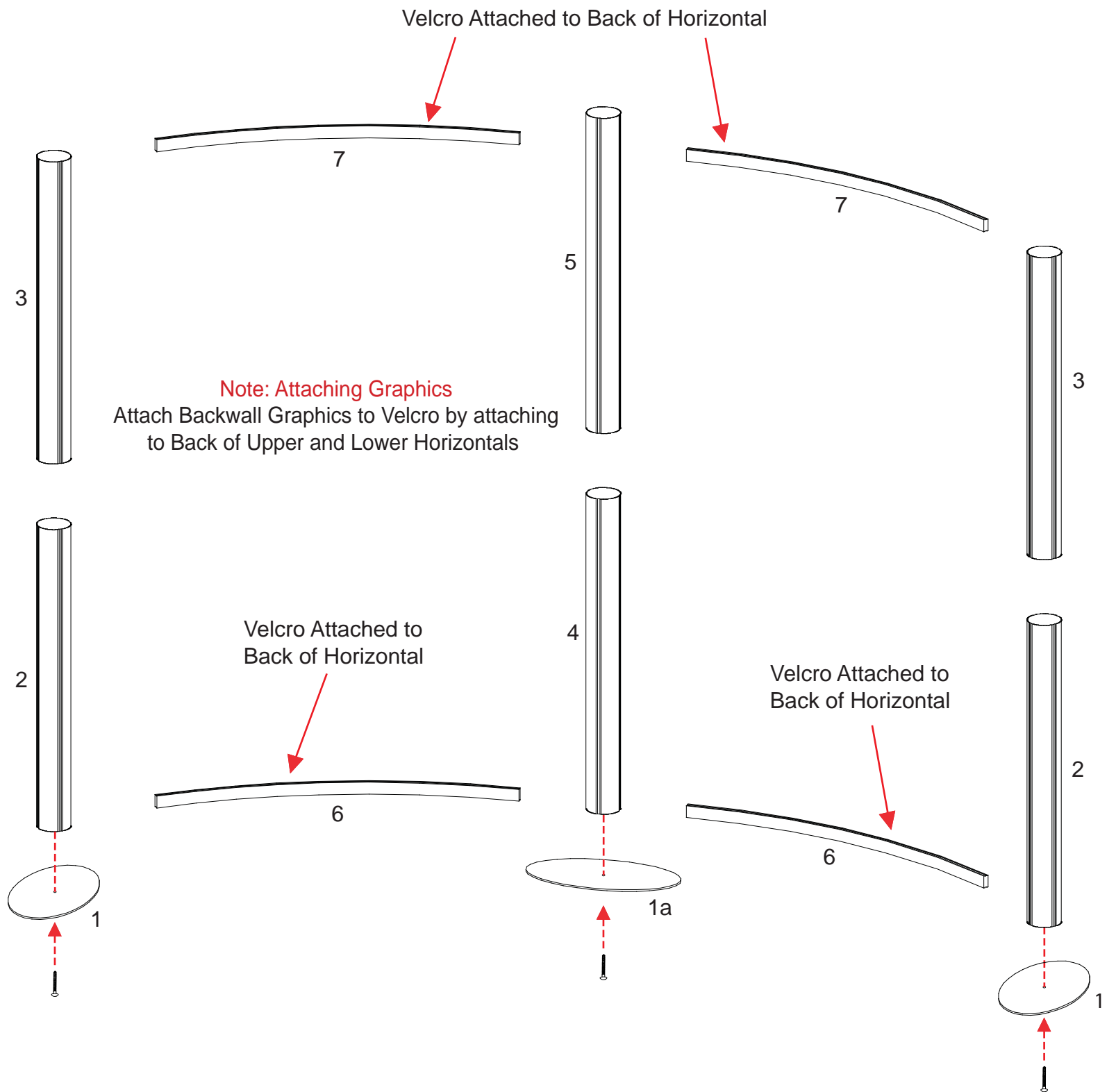
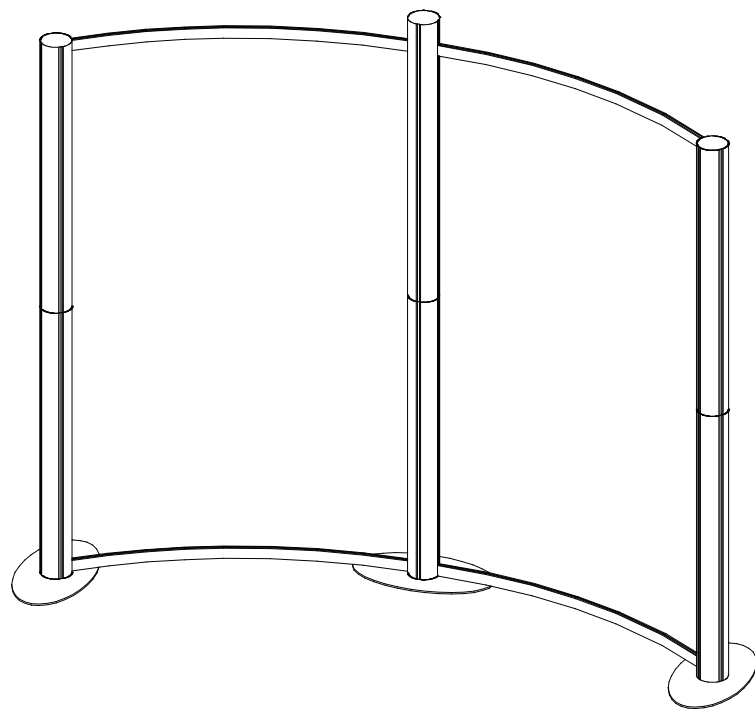

WHEN DISASSEMBLING ALUMINUM EXTRUSION, TIGHTEN ALL SETSCREWS AND LOCKS TO PREVENT LOSS DURING SHIPPING

866.652.2100

Part Number	Qty for Step	Description
8	2	37.75h Vertical extrusion
9	1	37.75h Vertical extrusion
10	5	36.8"w Horizontal Extrusion
11	2	31.99"w Curved Horizontal Extrusion
12	2	T Connector
13	2	31.99"w Curved Horizontal Extrusion
14	2	13.7905"h Vertical Extrusion
15	2	10.65"w Stand-off Extrusion

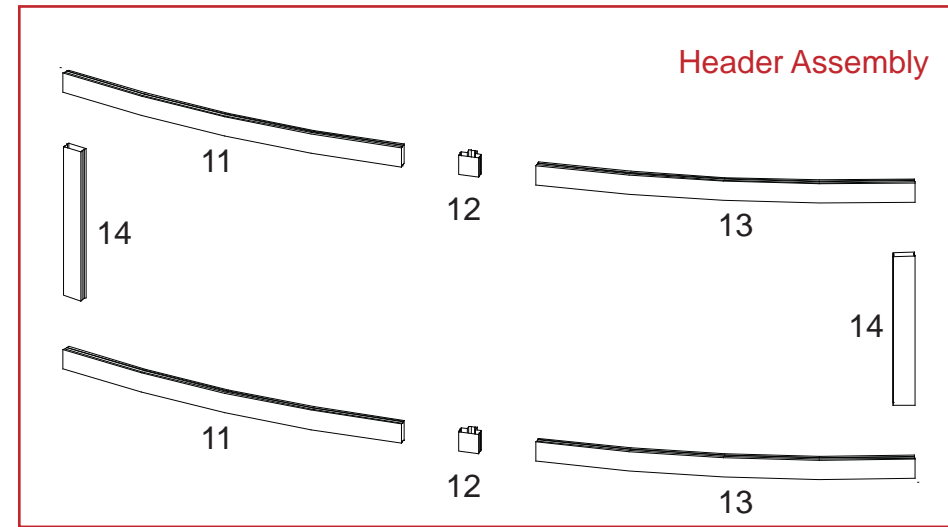

Steps

- 1) Assemble header pieces together, see Header Assembly detail.
 - 2) Attach assembled header to vertical extrusion where indicated using stand-off extrusions [15].
 - 3) Attach horizontal extrusions [10] to assembled backwall as indicated.
 - 4) Assemble counter base by attaching horizontal extrusion [9] between vertical extrusions [8].
- NOTE: Horizontal [9] must be flush with top of verticals [8].

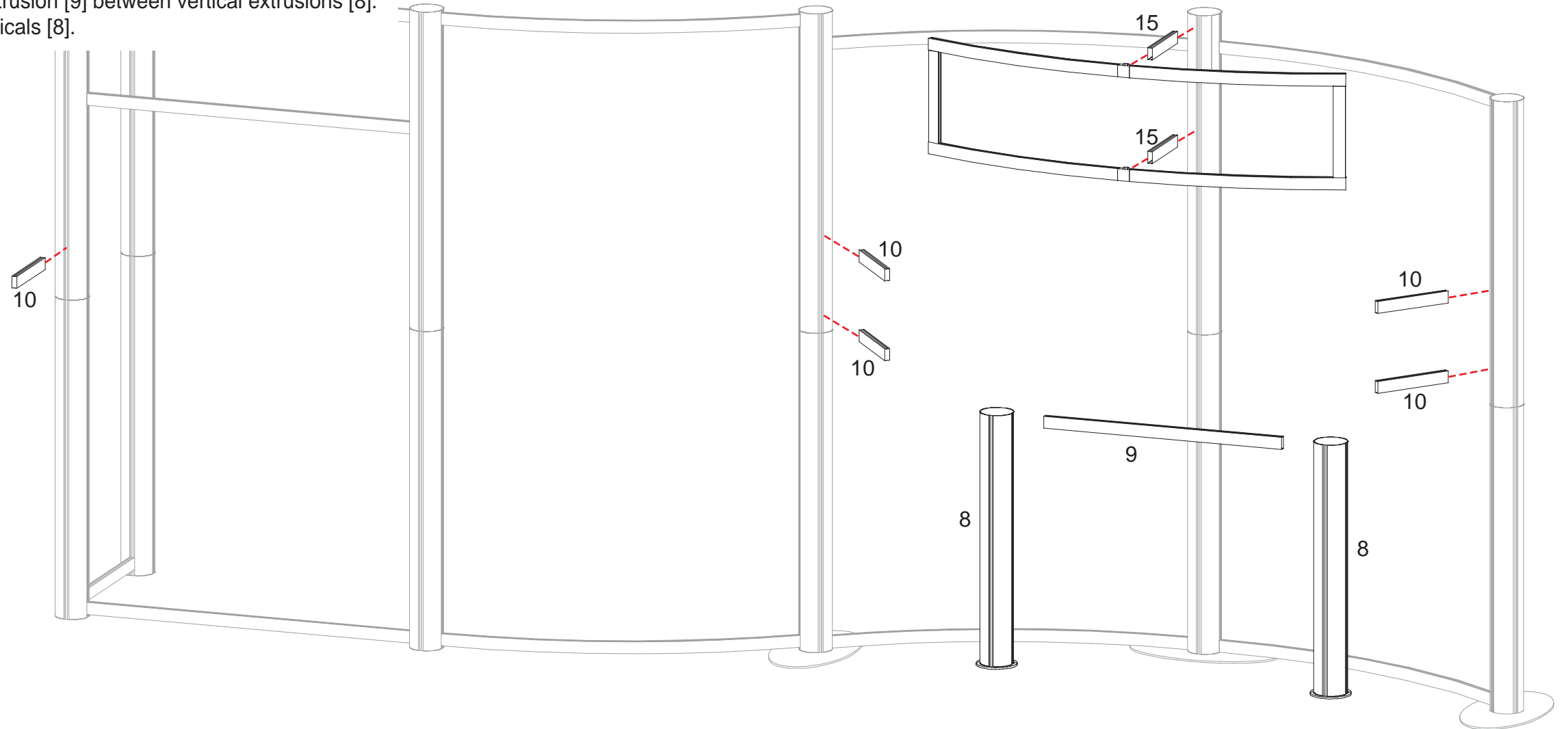

WHEN DISASSEMBLING ALUMINUM EXTRUSION, TIGHTEN ALL SETSCREWS AND LOCKS TO PREVENT LOSS DURING SHIPPING

Steps

- 1) Attach shelves to extrusions [10] using screw caps as shown.
- 2) Set counter atop base, and secure with thumbscrews to vertical extrusion.

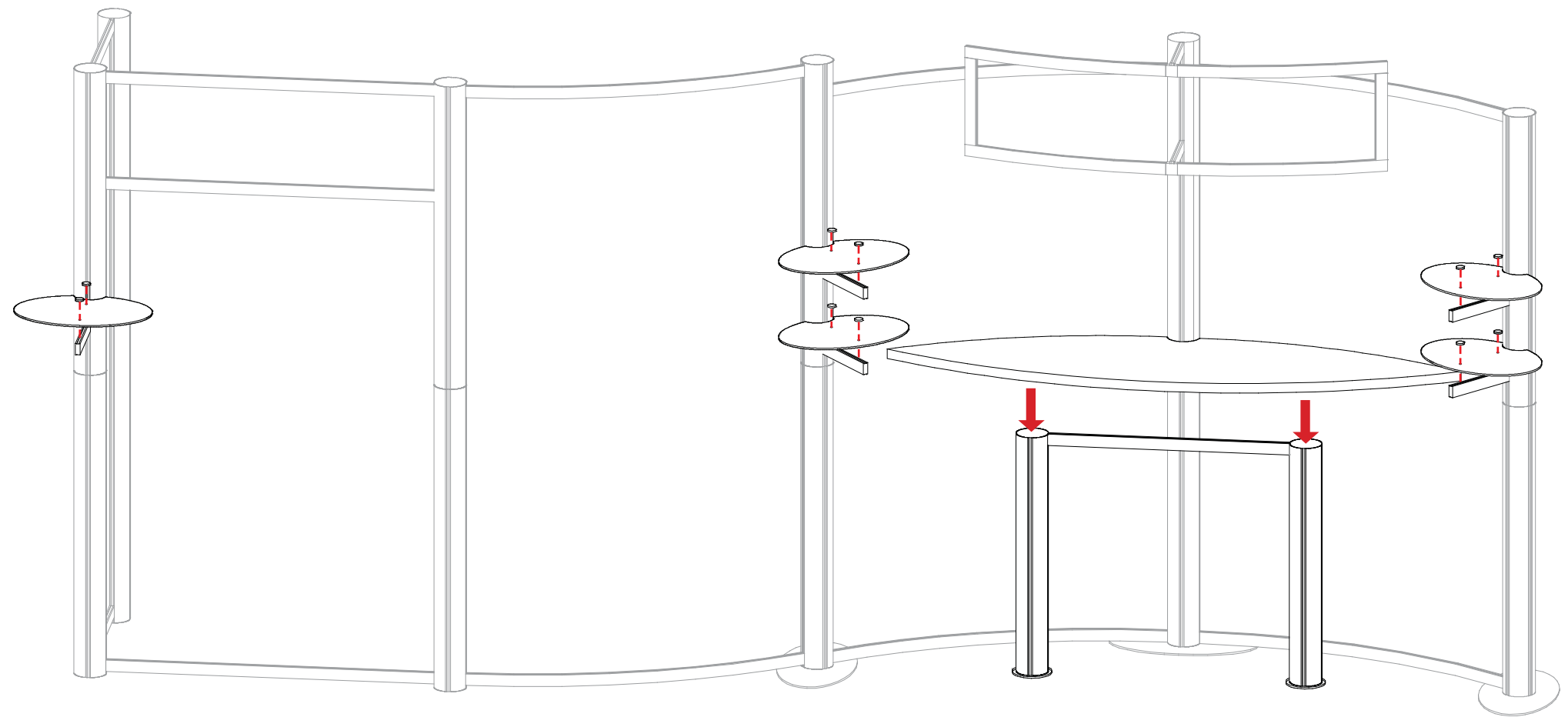
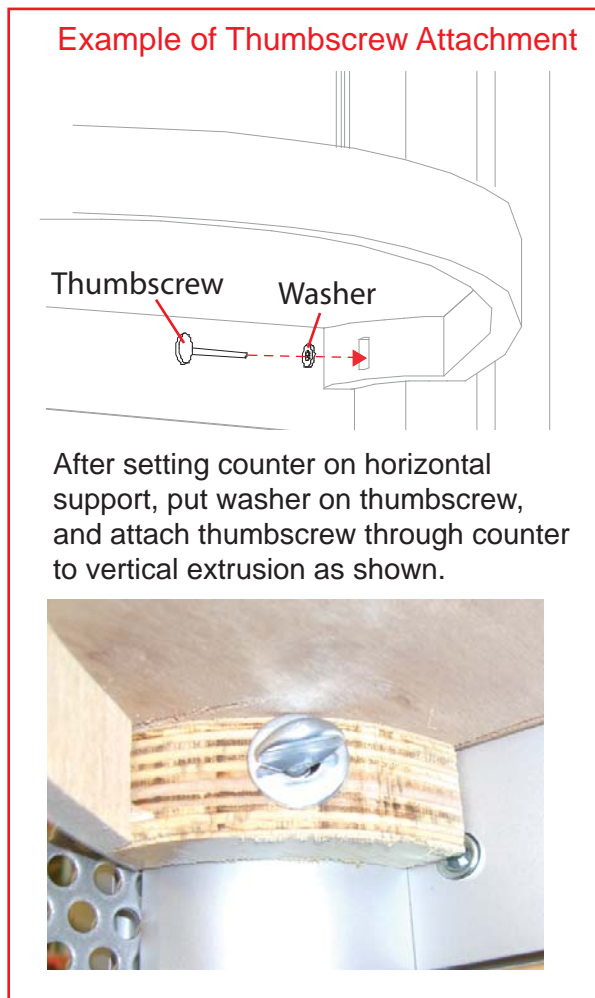

WHEN DISASSEMBLING ALUMINUM EXTRUSION, TIGHTEN ALL SETSCREWS AND LOCKS TO PREVENT LOSS DURING SHIPPING

866.652.2100

Item	Quantity	Description
16	1	38" h Round Vertical Extrusion
17	1	38" h Round Vertical Extrusion w/ Door Stopper
18	1	38" h Round Vertical Extrusion w/ Hinges
19	1	42" h Round Vertical Extrusion
20	2	31.85" Curved Horizontal Extrusion
21	2	23.8" Curved Horizontal Extrusion
22	4	16" Horizontal Extrusion

Steps:

- 1) Attach lower horizontal extrusions [20, 21 and 22] between vertical extrusions [16, 17, 18 and 19] as shown.
- 2) Place inserts and door where indicated.
- 3) Attach upper horizontal extrusions [20, 21 and 22] between vertical extrusions [16, 17, 18 and 19].
- 4) Velcro internal shelf supports to inside assembled pedestal
- 5) Set internal shelf atop shelf supports
- 6) Place counter atop assembled base.

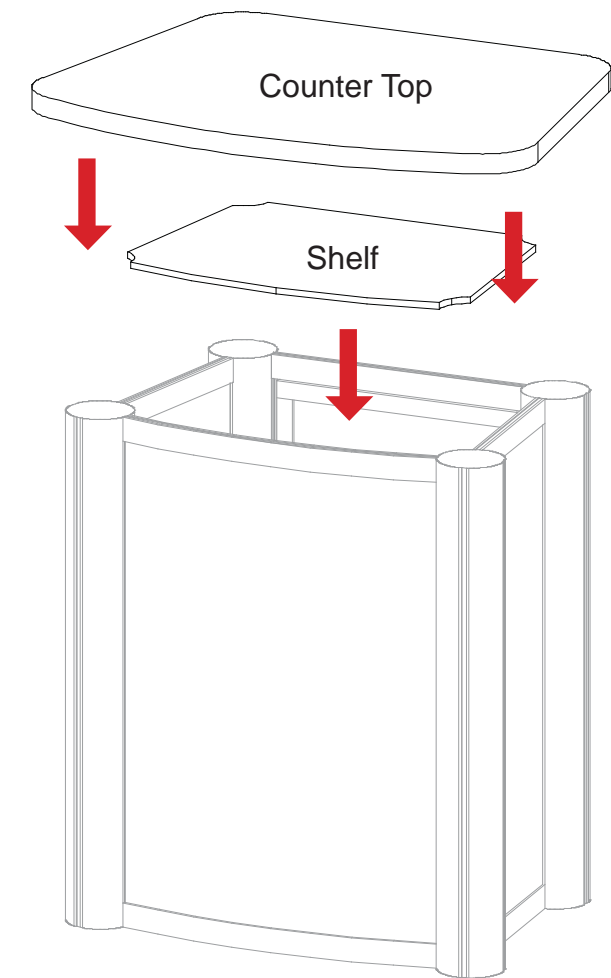
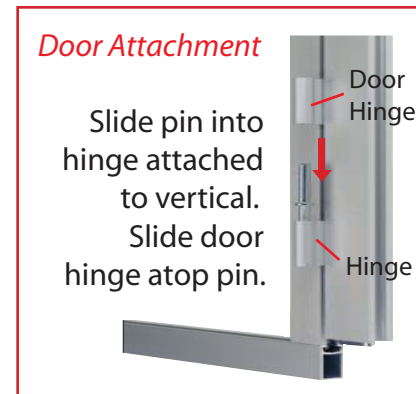
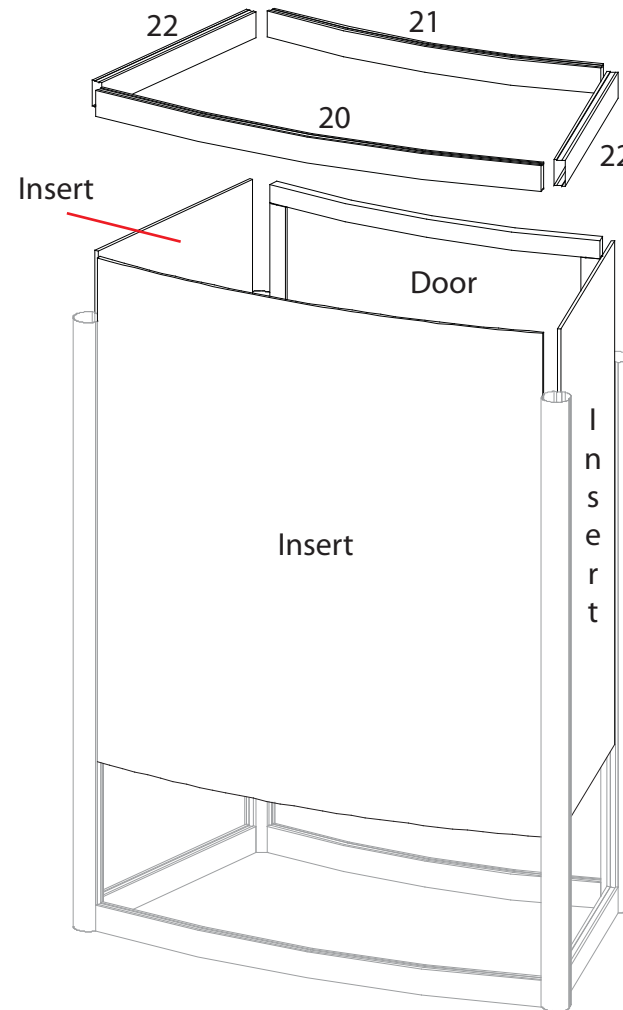
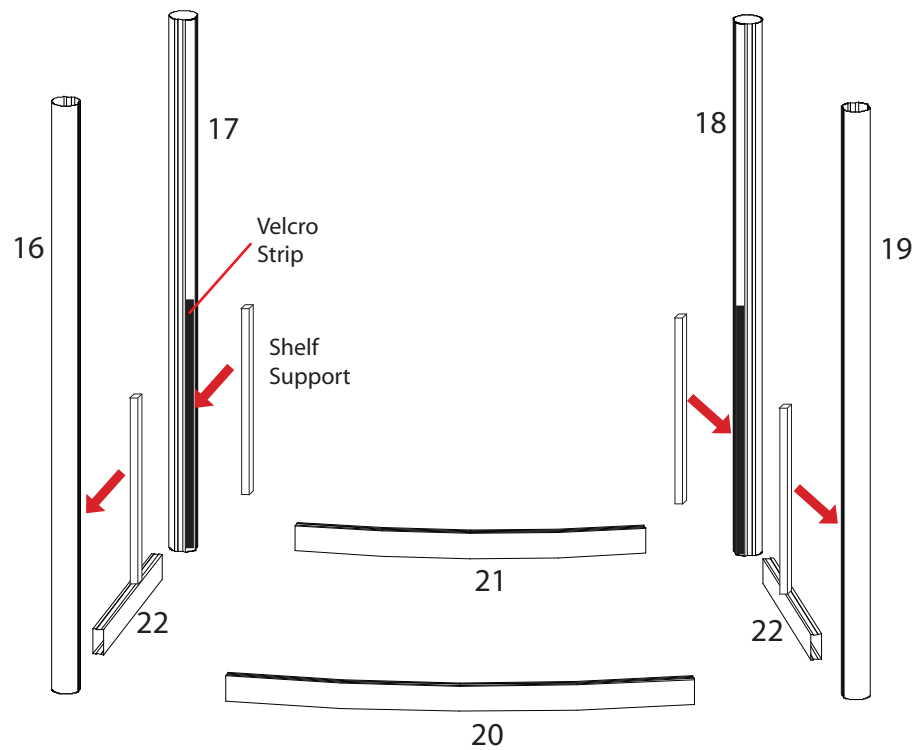
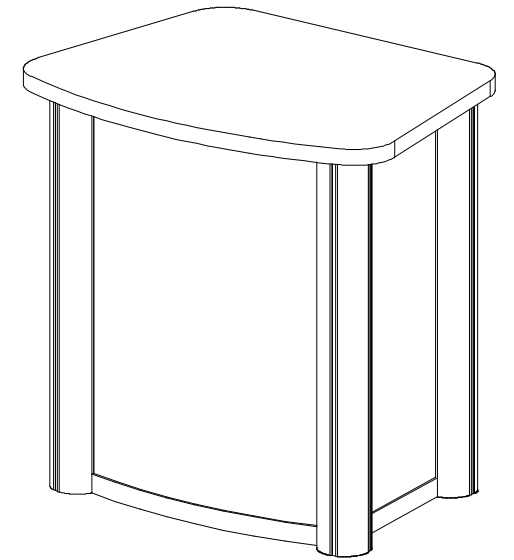

WHEN DISASSEMBLING ALUMINUM EXTRUSION, TIGHTEN ALL SETSCREWS AND LOCKS TO PREVENT LOSS DURING SHIPPING

866.652.2100

Part Number	Qty for Step	Description
32	2	Base Plate
33	2	42" h Lower Vertical extrusion
34	2	42" h Upper Vertical extrusion
35	1	23" w Horizontal Extrusion
36	1	23" w Horizontal Extrusion
37	1	23" w Horizontal Extrusion

Steps

- 1) Attach vertical extrusions to base plates [33 to 32].
- 2) Attach upper horizontal extrusions together [34 to 33].
- 3) Horizontal extrusions [35, 36 and 37] between vertical assemblies, placing insert as indicated.
- 4) Apply graphic to assembled stand.
- 5) Attach literature racks where indicated, see Literature Rack Attachment detail.

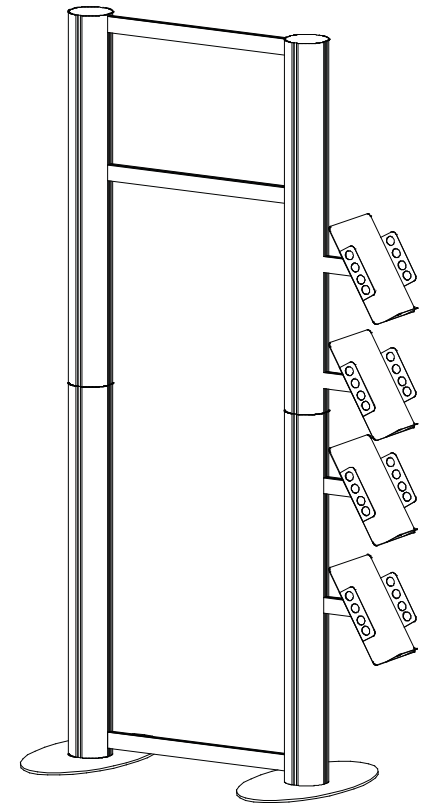
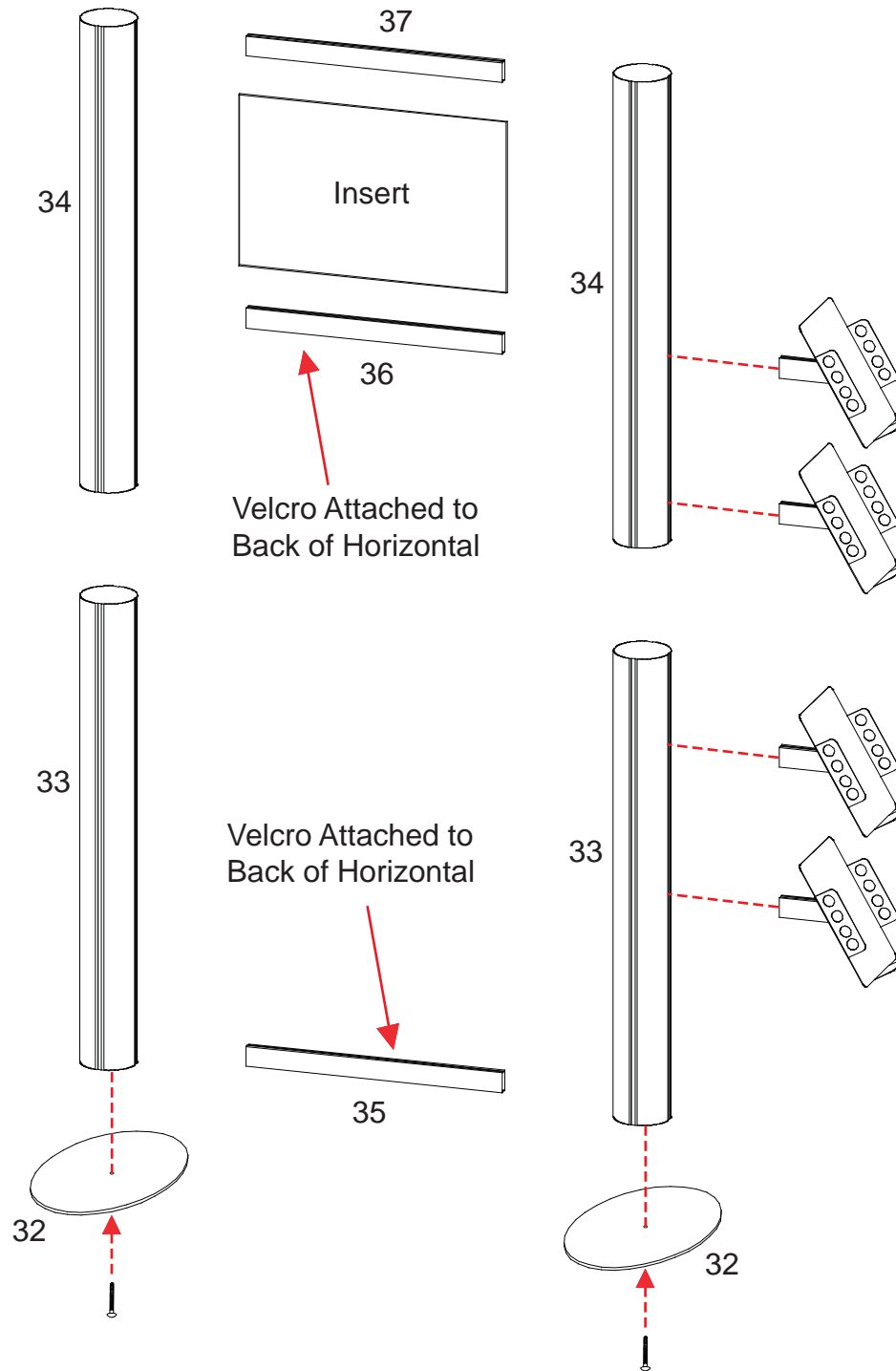
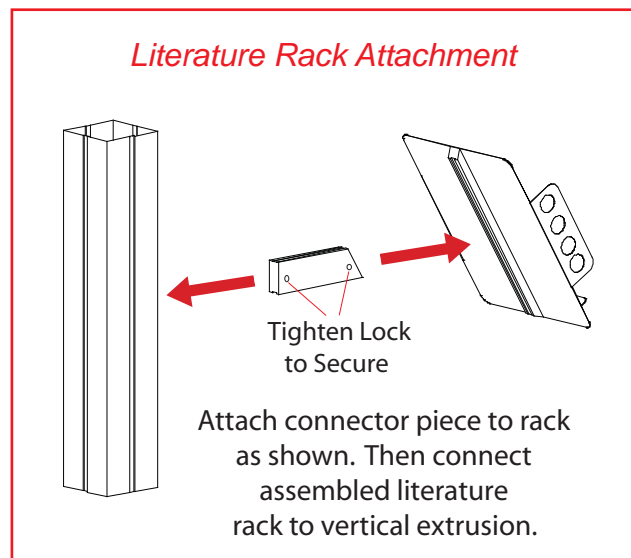

WHEN DISASSEMBLING ALUMINUM EXTRUSION, TIGHTEN ALL SETSCREWS AND LOCKS TO PREVENT LOSS DURING SHIPPING